

NEW model

star

CNC SWISS TYPE AUTOMATIC LATHE

SR-32JII



A modular design offering greater flexibility

The Modular Design increases the machine flexibility for the User

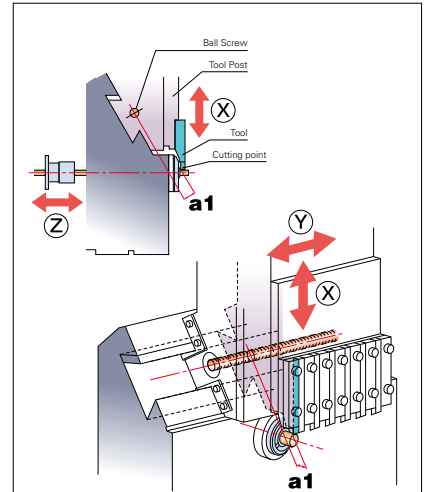
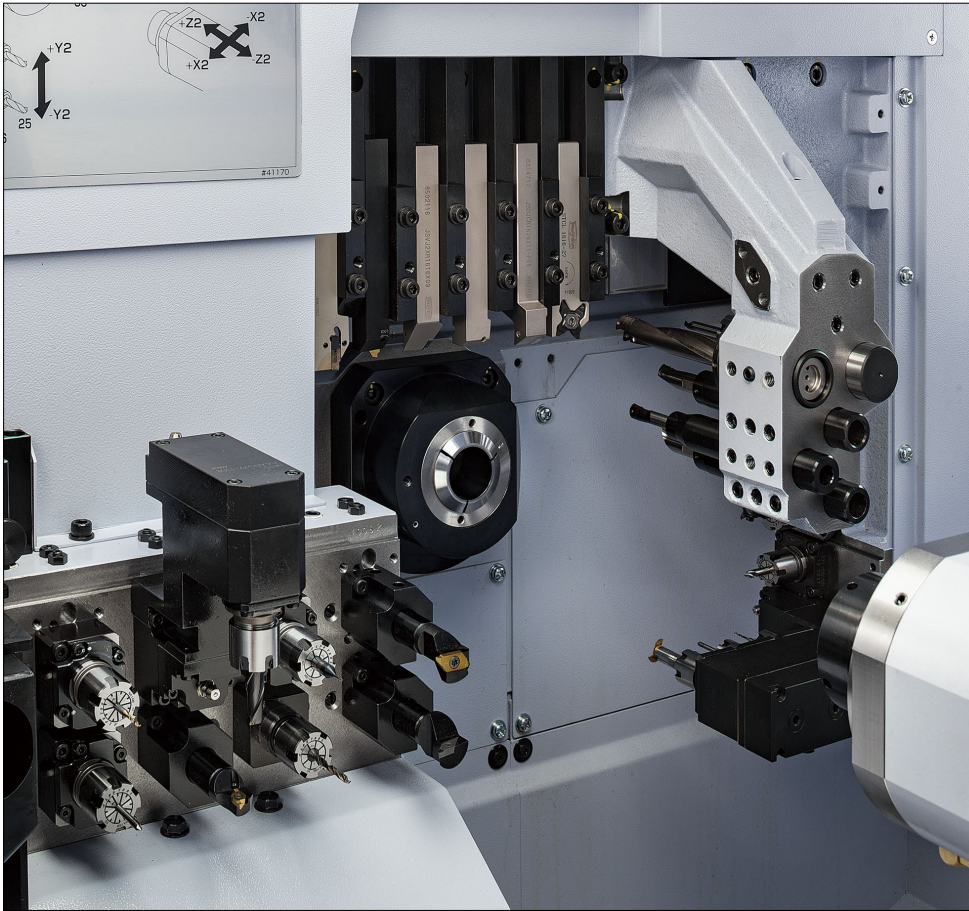

Slanted slide guideway structure

High rigidity tool post

The Y-axis slideway of the tool post incorporates a slanted dovetail structure. The X and Y-axis slideways are positioned close to the cutting point, which improves machine rigidity and stability. In addition, a straight line, passing through the ball screw center which is parallel to the Y-axis slideway and the cutting point are close to each other (a1), reducing the moment load caused by cutting resistance and thereby improving rigidity.

High Rigidity and High Accuracy

- A slant-type slide guideway structure on the Y axis is standard on all models.
- A highly rigid spindle sleeve guide system is used in N.G.B mode to further increase rigidity.

High rigidity head stock for non-guide bush type

- Original non-guide bush type
- Spindle Sleeve Slideway Structure (SR-32JI)

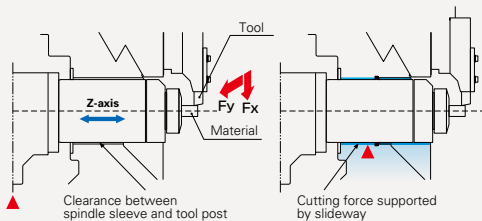

- A slanted dovetail structure is incorporated in the type B Y2 slideway to further improve rigidity of the backworking tool post.
- The main and sub spindles employ a built-in structure to enhance spindle indexing accuracy.

High Function and Machining Ability

- The G.B. and N.G.B change-over mechanism is introduced.
- The cross drilling unit includes two types, a 5-spindle type (three cross drilling units ER20 + 2-position cartridge) and a 6-spindle type (ER16 x 6 pcs.).
- Type A is equipped with a 6-spindle type and Type B is equipped with Y-axis control/8-spindle type backworking tool post.
- The backworking tool post now features increased pitch centres for 32mmØ OD turning without interference with the other tool stations.
- Type B backworking 8-spindle unit can accommodate a power tool unit in all positions as standard.
- Type A allows a power tool unit at all positions of the backworking 6-spindle unit by selecting the tool rotation drive unit (B) optionally.



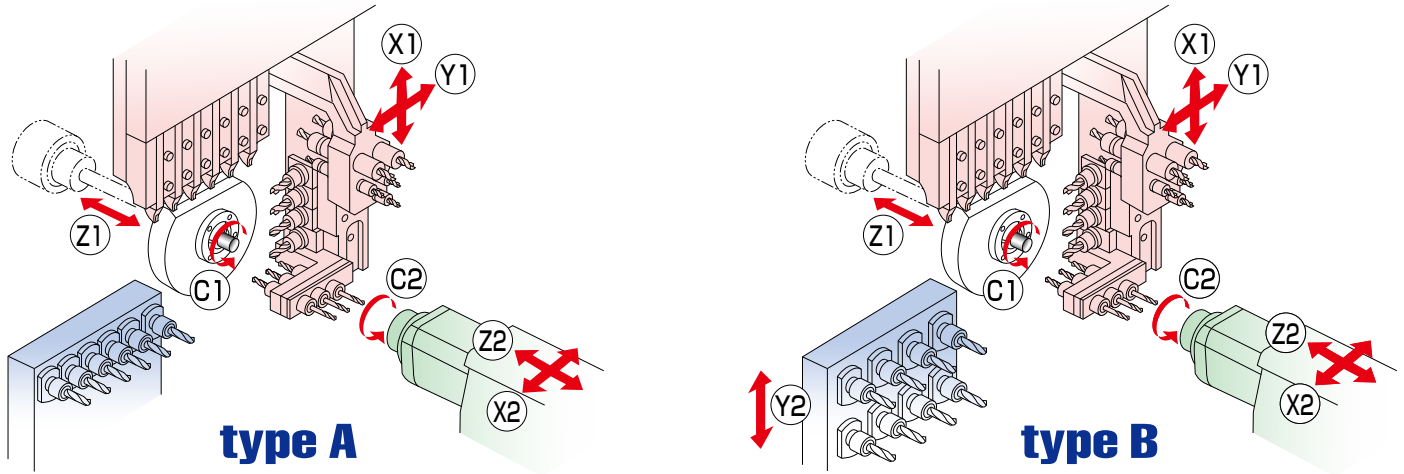

Operability and Workability

- Design features combining a large up and over door, reduced distance from the machine front to the guide bush, and a lowered threshold height into the working area further enhances the operator's accessibility.
- The movable operation panel enables operation at the best position suited to the operator.

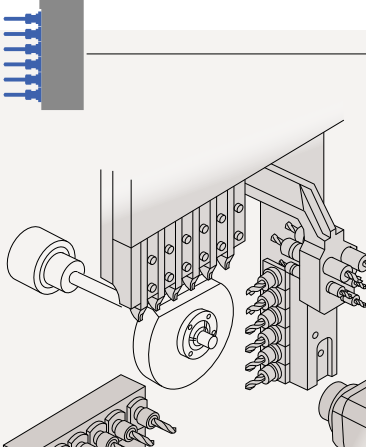

Model Variations to Select Optimum Functions

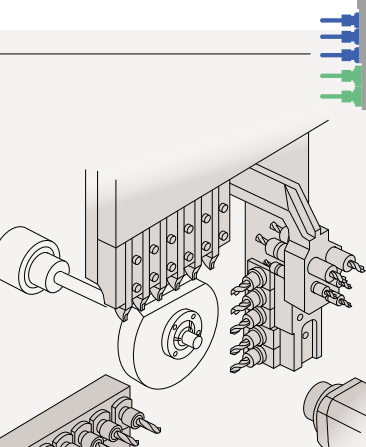
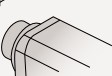
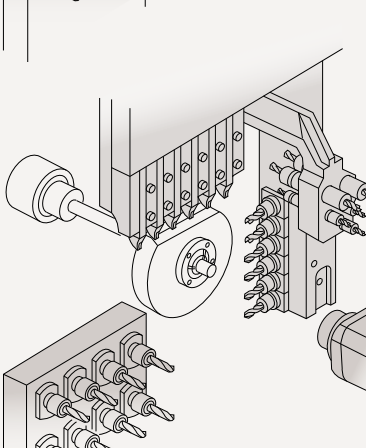
Star Micronics has introduced a modular design to the machines in order to respond to customers requirements for increased flexibility. Combining the functional modules facilitates development of variations to achieve the most appropriate machine configuration. The latest model SR-32JII incorporating a modular design includes two types A and B for the best choice suited to Customer's manufacturing conditions.

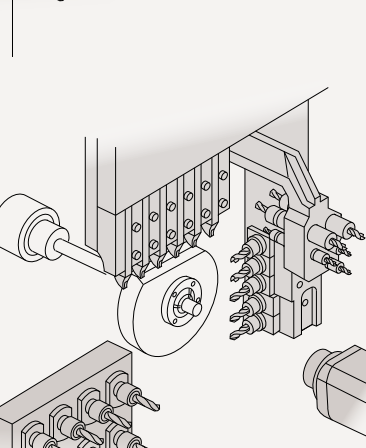
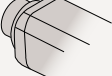
 <p>01</p> <p>6-spindle type cross drilling unit</p> <ul style="list-style-type: none"> <input type="checkbox"/> ER16x6 tools <p>Backworking 6-spindle unit</p> <ul style="list-style-type: none"> <input type="checkbox"/> Drive unit for power-driven attachment B (op) 	 <p>02</p> <p>5-spindle type cross drilling unit</p> <ul style="list-style-type: none"> <input type="checkbox"/> ER20x3 tools <input type="checkbox"/> Cartridge type 2Pos <p>Backworking 6-spindle unit</p> <ul style="list-style-type: none"> <input type="checkbox"/> Drive unit for power-driven attachment B (op) 
 <p>03</p> <p>6-spindle type cross drilling unit</p> <ul style="list-style-type: none"> <input type="checkbox"/> ER16x6 tools <p>Backworking 8-spindle unit with Y-axis control</p> 	 <p>04</p> <p>5-spindle type cross drilling unit</p> <ul style="list-style-type: none"> <input type="checkbox"/> ER20x3 tools <input type="checkbox"/> Cartridge type 2Pos <p>Backworking 8-spindle unit with Y-axis control</p> 

□ Standard Machine Specifications

Item	Specifications	
Max. machining diameter	φ32mm(1-1/4in)	
Max. headstock stroke	Standard	320mm(12-19/32in)
	R.M.G.B. type	286.5mm(11-9/32in)
	N.G.B. type	Bar diameter×2.5(Max.80mm)(Max.3-5/32in)
Tool	Number of tools	6 tools
	Tool shank	□16mm
5-Spindle sleeve holder	Number of tools	Front 5 tools
		Rear 5 tools
	Max. drilling capability	φ13mm(33/64in)
	Max. tapping capability	M12×P1.75
Power driven attachment	Number of tools	Cross milling 3 tools (ER20) + Cartridge type 2Pos
		Cross milling 6 tools (ER16)
	Max. drilling capability	φ10mm(25/64in)
	Max. tapping capability	M8×P1.25
	Spindle speed	Cross milling : Max.6,000min ⁻¹
		Cartridge-type tool : Max.8,000min ⁻¹
Drive motor	2.2kw(continuous)/4.0kw(5min./30%ED)	
Rapid feed rate	35m/min (X1, X2,Y1, Z1, Z2), 24m/min (Y2) : type B only	
Main spindle indexing angle	C-axis control	
Main spindle speed	Max.8,000min ⁻¹	
Main spindle motor	7.5kw(continuous)/11.0kw(10min./25%ED)	
Coolant tank capacity	255 ℓ	
Dimensions (W×D×H)	2,690×1,345×1,780mm	
Weight	4,100kg	
Power consumption	8.8KVA	
A-weighted sound pressure : note-1	Max.77dB	

□ Backworking Attachment Specifications

Item	Specifications		
Max. chucking diameter	φ32mm(1-1/4in)		
Max. length for front ejection	125mm(4-59/64in)		
Max. parts projection length	45mm(1-49/64in)		
Unit especially for backworking note-2	Number of tools	6 tools (type A)	
		8 tools (type B)	
	Max. drilling capability	Stationary tool	φ13mm(33/64in)
		Power driven tool	φ8mm(5/16in)
Max. tapping capability	Stationary tool	M10×P1.5	
	Power driven tool	M 6×P1.0	
Power-driven att. spindle speed	Max.6,000min ⁻¹		
Power-driven att. drive motor	1.0kw(continuous)/1.2kw(5min./30%ED)		
Sub spindle indexing angle	C-axis control		
Sub spindle speed	Max.8,000min ⁻¹		
Sub spindle motor	3.7kw(continuous)/5.5kw(10min./40%ED)		

□ External Dimensions and Floor Space

unit : mm(ft)

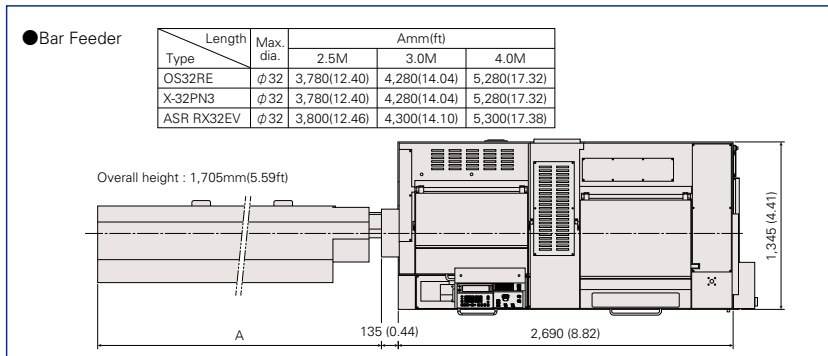

□ Standard Accessories and Functions

- CNC unit FANUC 32i-B
- Operation panel 10.4-inch color LCD display
- Manual pulse generator
- Pneumatic unit
- Hydraulic unit
- Coolant level detector
- Automatic centralized lubrication unit
- Door interlock system
- Cs contouring control (main/sub)
- Spindle clamp unit (Main / Sub)
- Spindle cooling unit
- Revolving guide bush unit
- Drive unit for revolving guide bush
- Air purge for revolving guide bush
- Main / Sub collet
- 6-station tool holder □16mm
- cross drilling unit (Gang type tool post)
- Drive unit for power-driven (Gang type tool post)
- 5-spindle sleeve holder
- Broken cutoff tool detector
- Backworking attachment
- Back 6-spindle unit ※TypeA
- 8-spindle backworking unit with Y axis control function ※TypeB
- Sub spindle air purge unit
- Drive unit for power-driven(Back 8-spindle unit) ※TypeB
- Parts conveyor
- Work light
- Leakage breake

□ Optional Accessories and Functions

- Coolant flow detector
- Water removal unit
- Oil mist filter
- Beacon
- Main spindle inner tube
- Rotary magic guide bush unit
- Non-guide bush type
- Feed arrow steady rest
- Drive unit for power-driven attachment B ※TypeA Only
- Parts ejector (Spring type)
- Parts ejector (Air cylinder type)
- Parts ejector with guide tube
- Parts stopper unit
- Coolant unit (6.9MPa/2.5MPa/0.7MPa)
- Coolant unit signal cable
- Coolant unit power cable
- Coolant valve
- Coolant pipings
- Automatic bar feeder interface
- LAN/RS232C interface
- Transformer
- Transformer CE marking version
- Transformer CE marking specifications

Note)

The machining capacities apply to SUS303 material. The machining capacities may differ from listed values depending on the machining conditions, such as the material to be machined or the tools to be used.

- note-1 : ● Measures conforming to ISO standard.
 ● A-weighted sound pressure is a general assessment standard characteristic that corrected the sound level to human acoustic sense.
- note-2 : ● In order to use the rotary tool, the driven system for power-driven tool type B is needed.(TypeA)

※Design features, specifications and technical execution are subject to change without prior notice.

※This product is an export control item subject to the foreign exchange and foreign trade laws. Thus, before exporting this product, or taking it overseas, contact your STAR MICRONICS dealer.

STAR MICRONICS CO., LTD.

Machine Tools Division

1500-34 Kitanoya, Misawa, Kikugawa, Shizuoka, 439-0023 Japan

America, Europe Sales TEL.+81-537-36-5594 FAX.+81-537-36-5607
 Asia Sales TEL.+81-537-36-5574 FAX.+81-537-36-5607

Star CNC Machine Tool Corporation
 123 Powerhouse Road, Roslyn Heights, NY11577, U.S.A.
 TEL.+1-516-484-0500 FAX.+1-516-484-5820

Star Micronics GB Limited
 Unit 1 Riverlands Business Park Raynesway DERBY DE21 7BZ
 TEL.+44-1332-86-44-55 FAX.+44-1332-86-40-05

Star Micronics GmbH
 Robert-Grob-Str.1,D-75305 Neuenburg, Germany
 TEL.+49-7082-7920-0 FAX.+49-7082-7920-20

Star Micronics AG
 Luelstrasse3, CH-8112 Otelfingen, Switzerland
 TEL.+41-43-411-60-60 FAX.+41-43-411-60-66

Star Machine Tool France
 90 Allee de Glaisy, ZI, 74300 Thyez Haute Savoie, France
 TEL.+33-450-96-05-97 FAX.+33-450-96-91-54

Shanghai Xingang Machinery Co., Ltd.
 2F, 229 Fute Rd.N. The China (Shanghai) Pilot Free Trade Zone
 TEL.+86-21-5868-2100 FAX.+86-21-5868-2101

Star Micronics (Thailand) Co., Ltd.
 289/23 M.13 Soi Kingkaew 25/1, Kingkaew Rd., T.Rachathewa A.Bangplee Samutprakarn 10540, Thailand
 TEL.+66-2-186-8945-47 FAX.+66-2-183-7845

<http://www.star-m.jp/eng/>

9001 | ISO 14001
 CERTIFIED

2016.09_Ver1.0_1